

KLIPIK CYCLONE ASSEMBLY TEKS

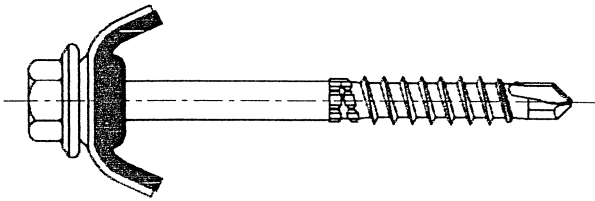

TIGHTEN SCREW SUCH THAT GASKET IS FIRMLY CLAMPED AND A LEAKPROOF JOINT OBTAINED

SCREW

PLATE

GASKET

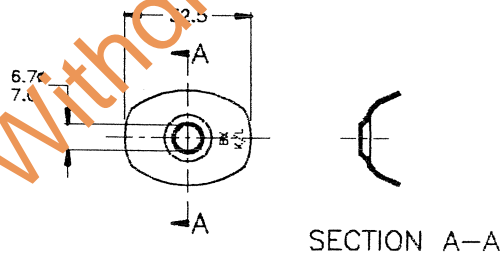
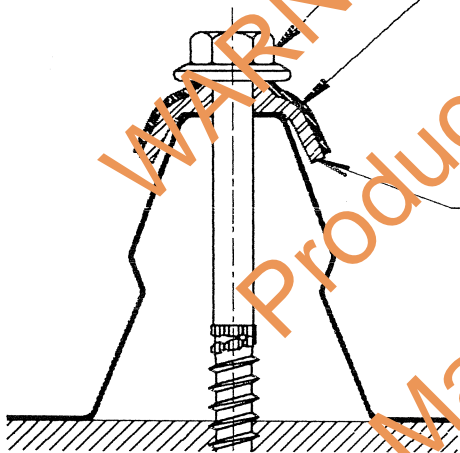

MATERIAL:	1.0mm STEEL STRIP TYPE G300
	TO ITW BUILDDEX SPECIFICATION 10-11-02
FINISH:	50um ZINCALLOY TO ITW BUILDDEX
	SPECIFICATION 80QC-009

PLATE

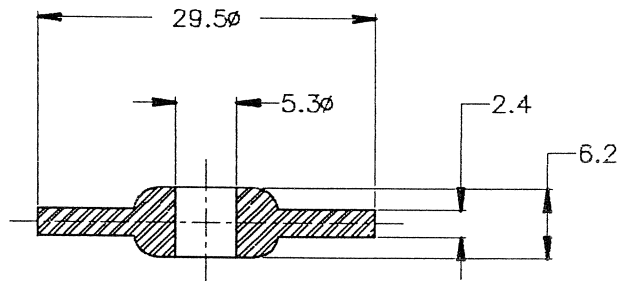

GASKET

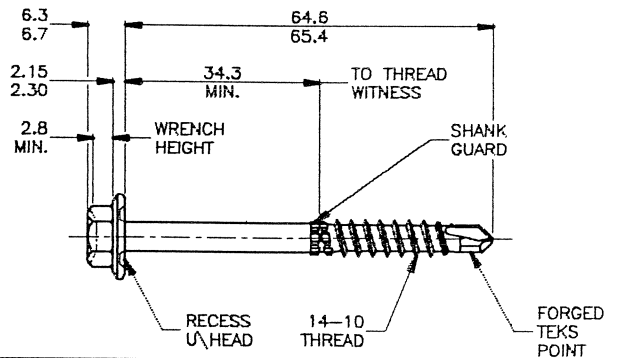
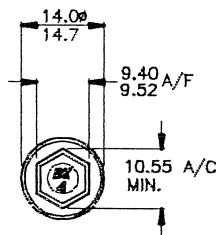

CONCENTRICITY	MATERIAL: STEEL 1022
HEAD TO SHANK: 0.25 T.I.R. MAX.	HEAT TREATMENT: CASE HARDEN
WASHER TO SHANK: 0.60 T.I.R. MAX.	FINISH: 50um ZINCALLOY TO ITW BUILDDEX
	SPECIFICATION 80QC-009

SCREW

14-10X65mm INDENTED HEX WASHER RECESSED
TEKS WITH SHANK GUARD

Approved for inclusion in the N.T. D.T.C.
by: BAC DATE 14/2/97

ITW Buildex
a division of W. A. Deutscher.
600 South Road Moorabbin, Vic. 3189
Phone (03) 9555 6433 Fax (03) 9532 0693

COLLESS AND O'NEILL PTY LTD
CONSULTING CIVIL AND STRUCTURAL ENGINEERS
84 Woods Street, Darwin, N.T. 0800
Phone (089) 81 8644 ACN 009 622 968
CERTIFIED DATE 7-2-97

DESIGN DATA SHEET

DARWIN CYCLONE AREA

DRG. No.

APPD. *[Signature]*

DATE
12.2.97

M/115/2