

Trimdek/Spandek Cyclone Assembly
TEKS

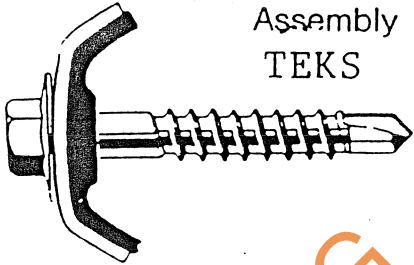

TIGHTEN SCREW SUCH THAT GASKET IS FIRMLY CLAMPED AND A LEAK-PROOF JOINT OBTAINED.

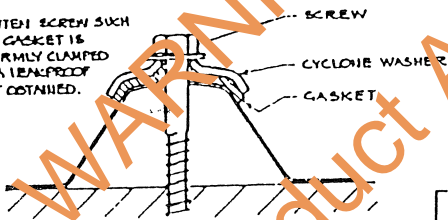

W.A.D. PRODUCT SPECIFICATION
14--10 X 50.0mm INDENTED HEAD WASHER RECESSED HEAD SCREWS WITH SHANK GUARD

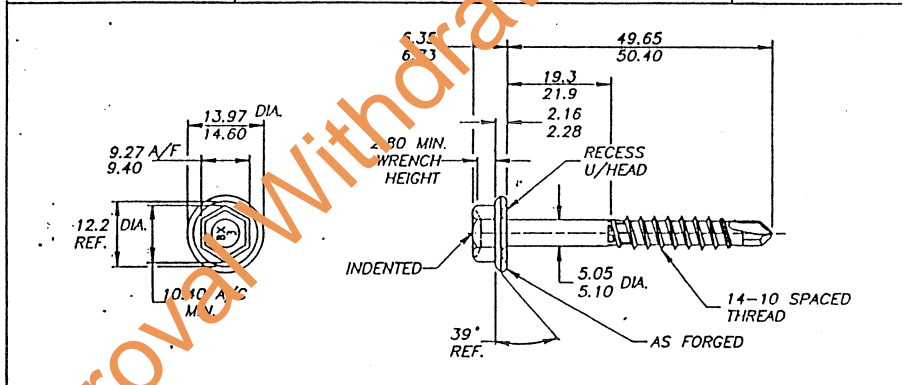

CONCENTRICITY:		MATERIAL: STEEL 1022	
HEAD TO SHANK:	0.25	T.I.R. MAX:	
WASHER TO SHANK:	0.50	T.I.R. MAX:	
		HEAT TREAT:	SURFACE HARDNESS 540-650 HV 5kg. CORE HARDNESS 320-390 HV 20kg. CASE DEPTH 0.13-0.18 mm.
		FINISH:	NOT DIPPED GALVANISED ✓

W.A.D. PRODUCT SPECIFICATION
CYCLONE PLATE SPANDEK/TRIMDEK

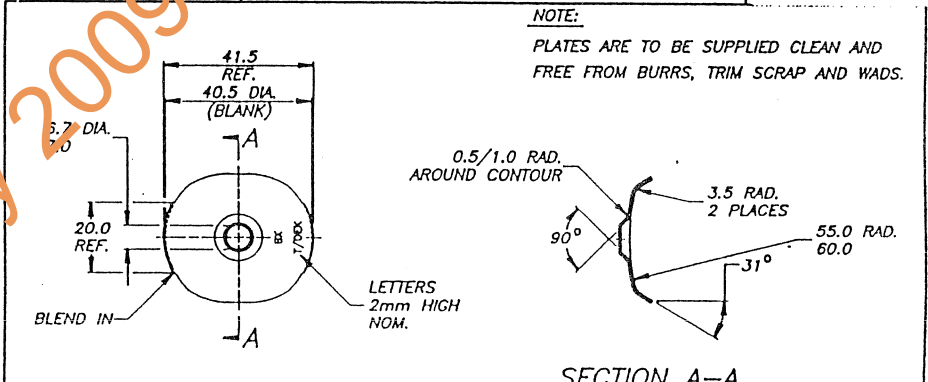

NOTE:
PLATES ARE TO BE SUPPLIED CLEAN AND FREE FROM BURRS, TRIM SCRAP AND WADS.

SECTION A-A

TOLERANCES: UNLESS OTHERWISE STATED	MATERIAL: 1.0mm ZINCALUME STRIP TYPE G300 AZ200
ANGULAR: ± 2°	TO W.A.D. SPECIFICATION 10-11-07
.0 ± 0.5	
.00 ± 0.2	

A	OD	35.4mm
B	Boss OD	12.3
C	Boss ID	5.4
D	Disc Width	26
E	OA Height	5.1
R	Curve Radius	1.8

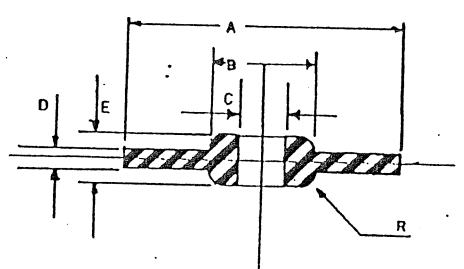

DESCRIPTION
DEKSEAL EPDM CYCLONE WASHER
No 14 FOR SPANDEK / TRIMDEK

MANUFACTURES NAME: W.A. DEUTSHER PTY. LTD. 600 SOUTH ROAD MOORABBIN, VIC.	FIXINGS FOR SPANDEK, TRIMDEK, AND HANDEK FOR STEEL. NORTHERN TERRITORY CYCLONIC AREAS.
APPROVED: <i>[Signature]</i> DATE: 4/2/91	DESIGN DATA SHEET DRAWING N°: M/115/5