

STEEL RIB 675 ROOF SHEETING

MATERIAL SPECIFICATION

METAL TYPE	THICKNESS	GRADE	FINISH	COVER
AS1397-1984	0.42mm BMT	550 MPa	ZINCALUME,	675mm + - 4
G550 / AZ150	0.48mm BMT	550 MPa	COLORBOND	

MINIMUM FIXING REQUIREMENTS

Fixing	No of Fixing	Cyclone Cap	Batten
14-10 Tek x 75mm	3	Squarelok	Steel 1.5mm G450
All fixings shall have Class 4 finish			
Screw length does not allow for insulation. Adjust screw length accordingly			

RA1 - KL = 1.5 - Upwind leading edges within "a" of the edge
 RA2 - KL = 2.0 - Upwind leading edges within "a"/2 of the edge
 RA3 - KL = 1.5 - Downwind side of hips and ridges within "a" of the edge - When roof pitch > or = 10°
 RA4 - KL = 2.0 - Downwind side of hips and ridges within "a"/2 of the edge - When roof pitch > or = 10°
 RC1 - KL = 3.0 for Roof pitch < 10° - Upwind corners within "a" of edge
 RC1 - KL = 2.0 for 10° and greater - Upwind corners within "a" of edge

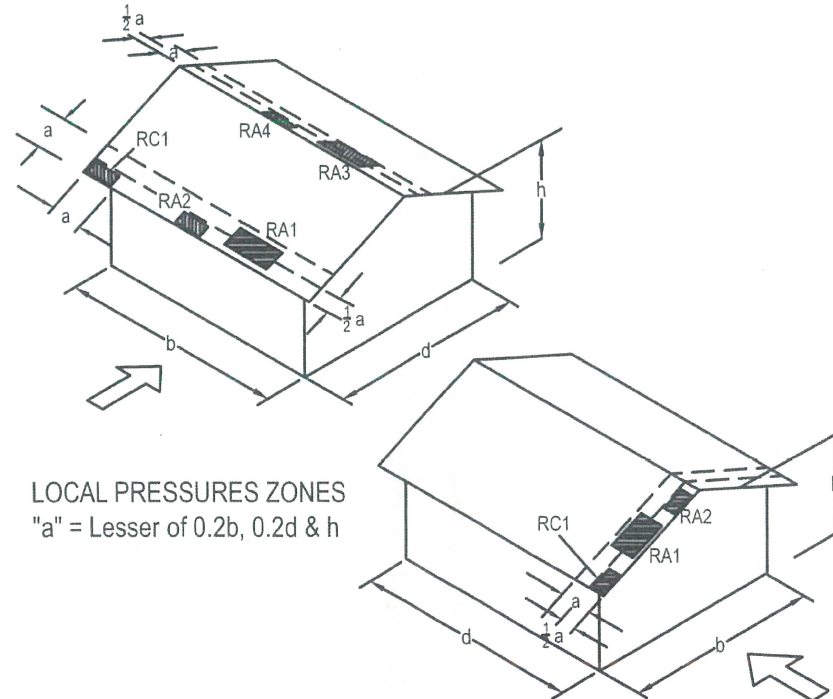

MAX. ALLOWABLE ROOF SHEETING SPANS

Vsit,β (m/s)	qu (KPa)	KL Local Factor	Pe (K/a)	0.42mm Sheeting	0.48mm Sheeting
70	2.34	1.0	4.70	1250	1500
		1.5	6.03	980	1150
		2.0	7.35	800	950
		3.0	10.00	600	720
67	2.59	1.0	4.31	1300	1650
		1.5	5.52	1050	1300
		2.0	6.73	880	1050
		3.0	9.16	650	780
61	2.23	1.0	3.7	1600	1800
		1.5	4.58	1300	1550
		2.0	5.58	1050	1290
		3.0	7.59	780	950
56	1.88	1.0	3.01	1800	2000
		1.5	3.86	1450	1800
		2.0	4.70	1200	1450
		3.0	6.40	900	1050

Tabled values are for 3 or more spans of sheeting installed. For single span sheets maximum spans above shall be limited to 1200mm.

For double spans - adjust values above to 90%

Product Name

Steeline SteelRib 675 Sheeting for Roofs

Product Description

SteelRib 675 Screw Fixed Roof Sheeting

Manufacturer's Name

GENERAL ROOFING PRODUCTS PTY LTD
 24 Pruen Road, Berrimah, NT, 0828

DESIGN CRITERIA

- Wind speeds, pressures shall be determined in accordance with AS/NZS1170.2-2011 Amndt 3, Structural Design Actions - Wind Actions,
- Internal Pressure Coefficient Cpi = +0.7
- Cpe = 0.9 for h/d ratios <= 0.5
- Pe = qu x (Cpe x KL + Cpi)
- "a" = Minimum of 0.2*d or 0.2*b or h
- Site wind speed calculated in accordance with AS1170.2

Limitations

- Tabled Results are for 3 or more spans of installation.
 - For Single Span sheets - Tabled Values and Max span 1200mm
 - For double spans - adjust results to 90% of tabled values
- For roof pitch < 10° note RC1 zone local factor in roof corners
- Limited to Heights "h" less than 25m
- Tabled Spacings are limited to h/d not greater than 0.5. For h/d>0.5 where Cpe > 0.9, refer to site specific engineer certification with adjusted Pe calculation.
- Installation requires conventional edge flashing is installed over unapped edge sheets.
- Sheeting overhang off edge purlin shall be limited to 150mm.
- Foot traffic limits for normal loading shall be 1200mm for end spans and 1800mm for mid spans. Feet may be positioned in the pan of the sheet.

Accepted for Inclusion

DTCM ref: M/291/01

Chairman's Signature:

Chairman's Name:

STEVEN J STRUCH

Date of Approval: 7 July 2016 Expiry Date: 6 July 2021

Notes covering basis of DTC (relevant test reports etc)

Test Report - The above specification is based on LHL testing Report No TS654 by James Cook University dated April 3, 2007.

*Checking Engineers Certification

Name: Phil Low
 RPEQ No: 6307
 Date: 03 Dec 2015
 Signature:

**Certifying Engineers Certification

Name: John L Towler
 NT Rego Number: 24642ES
 Date: 03 Dec 2015
 Signature:

**registered as a structural engineer in Northern Territory