

IN ACCORDANCE WITH NCC VOLUME 2 (SECTION P3.10.1), THIS PRODUCT SATISFIES PERFORMANCE REQUIREMENT P2.1.1 FOR CONSTRUCTION IN A HIGH WIND AREA.

CYCLONE ASSEMBLY COMPONENTS

Comprising of self drilling screw & one piece cyclone washer

TYPE 17 WITH BRA WASHER CYCLONE ASSEMBLY

FOR METAL BATTENS & TIMBER BATTENS

14g -10x50/65mm
(HEAD MARKING B4 & BF)



BREMICK BRA - CYCLONE WASHER / SEAL
ONE PIECE ALUMINIUM / EPDM CYCLONE WASHER

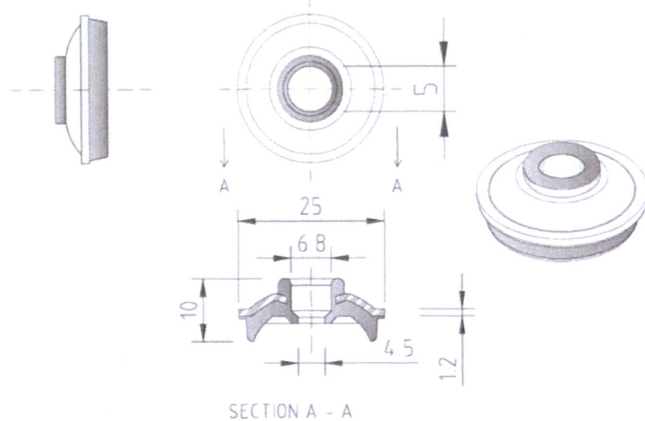

All dimensions mm (nominal)

Testing was undertaken at the James Cook University Cyclone Testing Station. Tested and approved in accordance with the requirements of AS/NZS 1170.2 : 2011 - Structural design actions - Wind actions and NCC 2016 Vol.I Specification B.1.2 and NCC 2016 Vol. II Section 3.10.1.

Test Certificate Numbers

JCU Cyclone Testing Station Report No.'s TS 1037 & TS 1038

FASTENING:
STRAMIT CORRUGATED
0.42mm BMT G550 min.



FASTENING TO:
METAL BATTENS
0.75mm BMT min.
G550 min.
TIMBER BATTENS
JD3 min.

FASTENING:
STRAMIT MONOCLAD
0.42mm BMT G550 min.

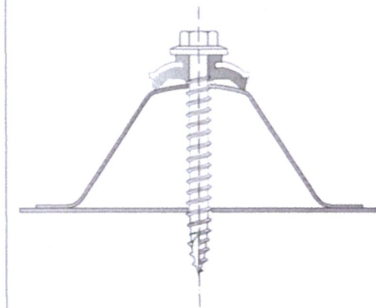

FASTENING TO:
METAL BATTENS
0.75mm BMT min.
G550 min.

CORRUGATED ROOFING PROFILE - STRAMIT CORRUGATED

FASTENER SPACINGS

Crest Fastener Locations : Alternate Ribs (152mm Centres)
Spans Tested : 900mm End, 1150mm Intermediate, 900mm End

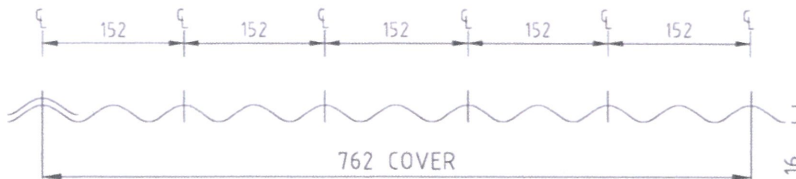

Supports	Crest Fixing	Side Lap Fixing
Metal Battens 0.75mm BMT min. G550 min.	Bremick Type 17 14-10x50 BRA	Bremick Vortex™ Stitch M6.5-13x20 (900 mm Centres min.)
Timber JD3 min.		

SQUARE RIB ROOFING PROFILES - STRAMIT MONOCLAD

FASTENER SPACINGS

Crest Fastener Locations : Each Rib (190mm Centres)
Spans Tested : 1200mm End, 1500mm Intermediate, 1200mm End

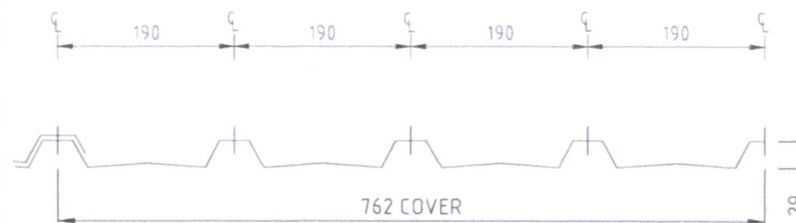

Supports	Crest Fixing	Side Lap Fixing
Metal Battens 0.75mm BMT min. G550 min.	Bremick Type 17 14-10x65 BRA	Bremick Vortex™ Stitch M6.5-13x20 (900 mm Centres min.)

Product Name

TYPE 17 BRA Cyclone Assembly

Product Description : Roofing Fasteners

T17 14-10x50/65 - BRA Cyclone Assembly
With Stramit Profiles

Manufacturer's Name: BREMICK Pty Ltd
F1, 62 Maddox Street
Alexandria NSW 2015
Ph: 02 8332 1501
Email: sales@bremick.com.au

Design Criteria

Fastener & support spacing to be controlled such that the maximum design loading per fastener or maximum design pressures do not exceed:

Table 1 : Strength Limit State Design Loads per Fastener

Roofing Profile	Test Load (kN)	C.O.V. (K _t)	Design Load (kN)
Corrugated	0.96	1.46	0.66
Monoclad	1.30	1.46	0.89

Table 2 : Strength Limit State Design Pressures

Roofing Profile	Test Pressure (kPa)	C.O.V. (K _t)	Design Capacity (kPa)
Corrugated	5.52	1.46	3.78
Monoclad	4.54	1.46	3.11

Limitations

This sheet confirms the structural adequacy of the roof sheeting assembly (sheeting, screw and washer) when correctly installed and does not extend to the capacity of the batten/purlin. Refer to the sheeting & batten manufacturers data for maximum support spacings.

Strength limit state fastener loads have been derived from the test pressures using simplified static analysis with the uniform pressure (load) distribution.

The fastener is only applicable for use with Stramit cladding products with the conditions in this data sheet.

Accepted for Inclusion

DTCM ref: M/818/01

Chairman's Signature:

Chairman's Name:

STEVEN J EHRlich

Date of Approval: 11/05/2017 Expiry Date: 11/05/2022

*Checking Engineers Certification

Name: RACHAEL ZEJWER
Registration Number: NPER 11734
Date: 6/2/2017
Signature: Rzejwer

*registered as a structural engineer in Australia

*Certifying Engineers Certification

Name: TREVOR JOAN
NT Registration Number: 12170ES
Date: 23/2/17
Signature: TJoan

**registered as a structural engineer in the Northern Territory