

IN ACCORDANCE WITH NCC VOLUME 2 (SECTION P3.10.1), THIS PRODUCT SATISFIES PERFORMANCE REQUIREMENT P2.1.1 FOR CONSTRUCTION IN A HIGH WIND AREA

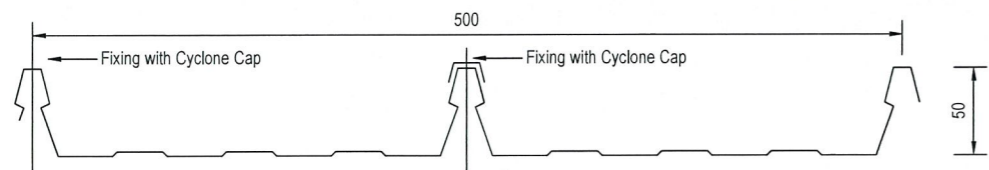

STEELINE STEEL RIB ROOF SHEETING

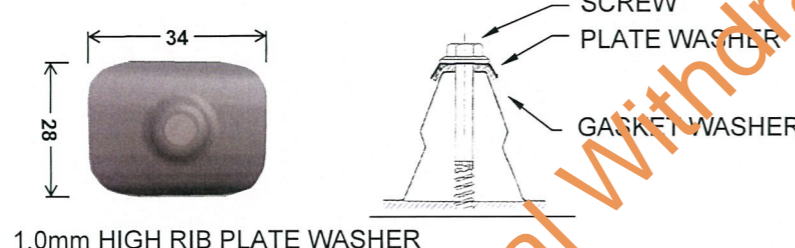

1.0mm HIGH RIB PLATE WASHER

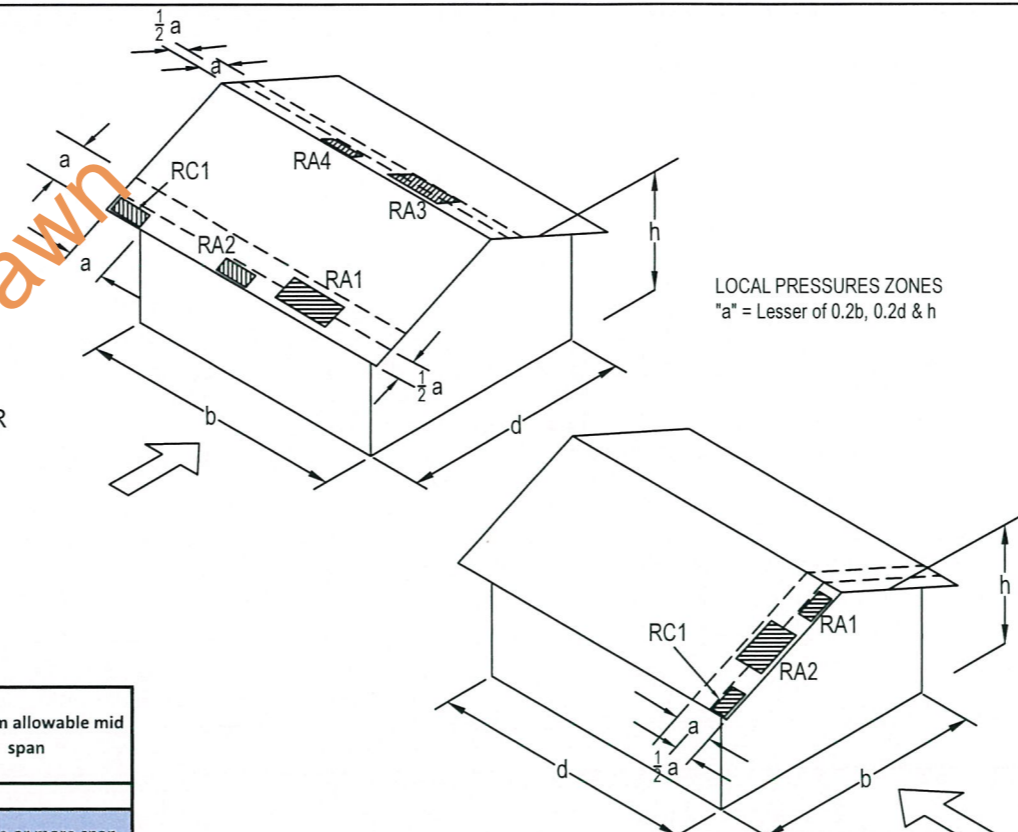

MAX. ALLOWABLE ROOF SHEETING SPANS FOR IMPORTANCE LEVEL 2 BUILDINGS

V _{sit} (m/s)	q _u (kpa)	KL local factor	Design pressure (kPa)	Maximum allowable end span						Maximum allowable mid span					
				Fixing with 14g-10 x 50 tek screw into 5 mm BMT G450 steel batten											
				For single span steel rib only		For double span steel rib only		For three or more span steel rib		For three or more span steel rib		For three or more span steel rib		For three or more span steel rib	
				Upward (compression on bottom)		Upward (compression on bottom)		Upward (compression on bottom)		Upward (compression on bottom)		Upward (compression on bottom)		Upward (compression on bottom)	
				0.42 BMT	0.48 BMT	0.6 BMT	0.42 BMT	0.48 BMT	0.6 BMT	0.42 BMT	0.48 BMT	0.6 BMT	0.42 BMT	0.48 BMT	0.6 BMT
				(mm)	(mm)	(mm)	(mm)	(mm)	(mm)	(mm)	(mm)	(mm)	(mm)	(mm)	(mm)
76	3.47	1	5.54	770	860	1000	1000	1000	1000	970	1080	1100	1230	1230	1230
		1.5	7.10	680	760	840	780	780	780	850	860	860	960	960	960
		2	8.66	620	690	730	640	640	640	700	700	700	790	790	790
		3	11.78	530	550	650	470	470	470	510	510	510	580	580	580
73	3.20	1	5.12	810	900	990	1080	1090	1090	1010	1120	1190	1330	1340	1340
		1.5	6.55	710	790	870	850	850	850	890	930	930	1040	1040	1040
		2	7.99	640	720	790	700	700	700	760	760	760	850	850	850
		3	10.87	550	610	680	510	510	510	560	560	560	630	630	630
69	2.86	1	4.57	850	950	1050	1140	1220	1220	1070	1190	1310	1410	1500	1500
		1.5	5.86	750	840	920	950	950	950	940	1040	1040	1170	1170	1170
		2	7.14	680	760	840	780	780	780	850	850	850	960	960	960
		3	9.71	580	650	720	570	570	570	630	630	630	700	700	700
66	2.61	1	4.18	890	990	1090	1190	1320	1330	1120	1240	1370	1470	1640	1640
		1.5	5.36	790	880	960	1040	1040	1040	980	1100	1140	1280	1280	1280
		2	6.53	710	790	870	850	850	850	890	930	930	1050	1050	1050
		3	8.89	610	680	750	630	630	630	680	680	680	770	770	770
61	2.23	1	3.57	960	1070	1180	1290	1430	1560	1210	1340	1480	1590	1770	1920
		1.5	4.58	850	950	1040	1140	1220	1220	1070	1190	1310	1410	1500	1500
		2	5.58	770	860	950	1000	1000	1000	960	1070	1090	1230	1230	1230
		3	7.59	660	740	810	730	730	730	800	800	800	900	900	900
56	1.88	1	3.01	1050	1170	1290	1400	1560	1720	1320	1460	1610	1730	1930	2130
		1.5	3.86	930	1030	1140	1240	1380	1450	1160	1290	1420	1530	1710	1780
		2	4.70	840	940	1030	1120	1190	1190	1050	1170	1290	1390	1460	1460
		3	6.40	720	800	880	870	870	870	900	950	950	1070	1070	1070
50	1.50	1	2.40	1180	1310	1440	1570	1750	1930	1470	1640	1810	1940	2160	2380
		1.5	3.08	1040	1160	1280	1390	1550	1700	1300	1450	1600	1720	1910	2100
		2	3.75	940	1050	1150	1260	1400	1490	1180	1310	1440	1550	1730	1830
		3	5.10	810	900	990	1080	1090	1090	1010	1120	1200	1330	1340	1340

RA1 - KL = 1.5 - Upwind leading edges within "a" of the edge
 RA2 - KL = 2.0 - Upwind leading edges within "a"/2 of the edge
 RA3 - KL = 1.5 - Downwind side of hips and ridges within "a" of the edge - When roof pitch > or = 10°
 RA4 - KL = 2.0 - Downwind side of hips and ridges within "a"/2 of the edge - When roof pitch > or = 10°
 RC1 - KL = 3.0 for Roof pitch < 10° - Upwind corners within "a" of edge
 RC1 - KL = 2.0 for 10° and greater - Upwind corners within "a" of edge

MATERIAL SPECIFICATION

METAL TYPE	THICKNESS	GRADE	FINISH	COVER
AS1397-1984	0.42mm BMT	550 MPa	ZINCALUME,	500mm +- 4
G550 / AZ150	0.48mm BMT	550 MPa	REPAINTED,	
	0.60mm BMT		COATED	
			COLORBOND	

MINIMUM FIXING REQUIREMENTS

Fixing	No. of Fixing	Cyclone Cap	Purlin
14-10 x 75 Tek Screw	2	Hi Rib	Steel 1.5mm

Note : - All fixings shall have Class 4 protection finish
 Screws to comply to AS3566.1 - 2002
 Self-drilling screws for the building and construction industries - General requirements and maniacal properties

Product Name
Steeline Steel Rib Roof Sheeting

Product Description
Steel Rib Screw Fixed Roof Sheeting

Manufacturer's Name
GENERAL ROOFING PRODUCTS PTY LTD
 24 Pruen Road, Berrimah, NT, 0828

DESIGN CRITERIA

- Wind speeds, pressures shall be determined in accordance with AS/NZS1170.2-2011 Amndt 3, Structural Design Actions - Wind Actions,
- Basic Regional Wind Velocity V_R = 69m/sec (R=500)
- Internal Pressure Coefficient C_{pi} = +0.7
- C_{pe} = 0.9 for h/d ratios <= 0.5
- P_e = q_u x (C_{pe} x K_L + C_{pi})
- "a" = Minimum of 0.2*d or 0.2*b or h
- Site wind speed calculated in accordance with AS/NZS1170.2-2011 Amndt 3, Structural Design Actions - Wind Actions

Limitations

- Pitch limitation is subject to drainage requirements and shall be checked separately.
- For pitch < 10° - note RC1 local zone in roof corners.
- Limited to h/d not greater than 0.5 in tabled spacings.
- M_t = M_s = M_d = 1.0
- Span tables are suitable for single spans, end spans and mid spans.
- Maximum overhang - 150mm
- Minimum purlin steel thickness for fixing - 1.5mm G450
- For h/d>0.5 where C_{pe} > 0.9 refer to site specific engineer certification with adjusted P_e calculation.
- Installation assumes conventional edge flashing is installed over unlappped edges of sheeting.
- For Buildings not greater than 25m in height

Accepted for Inclusion

DTCM ref: M/251/01

Chairman's Signature:

Chairman's Name: **Paul Nowland**

Date of Approval: 7/08/2018 Expiry Date: 7/08/2023

Notes
 Test Report - The above specification is based on LHL testing Report No C081001-19 by ENGTEST The University of Adelaide Australia
 And Test Report No 107 by Blanmore Noosaville Dated 31st August 2011.

*Checking Engineers Certification
 Name: Wisnu Lim
 NT Rego Number: 145651ES
 Date: 28 June 2018
 Signature:

**Certifying Engineers Certification
 Name: John L Towler
 NT Rego Number: 24642ES
 Date: 28 June 2018
 Signature:

**registered as a structural engineer in Northern Territory