

**CYCLONE ASSEMBLY COMPONENTS**

Comprising of self drilling screw & one piece cyclone washer

**VORTEX CYCLONE UNIVERSAL SCREW**

FOR METAL BATTENS, TIMBER BATTENS & STEEL PURLINS  
M6.2-13 x 55, 65 & 95mm  
(HEAD MARKING B8 & B8V)

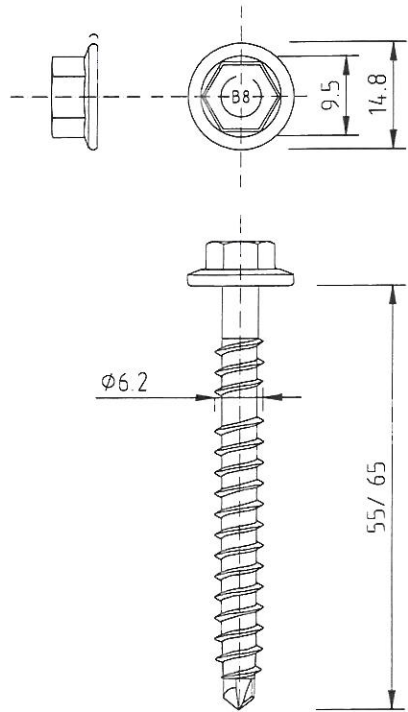

**BREMICK BRA - CYCLONE WASHER / SEAL**  
ONE PIECE ALUMINIUM / EPDM CYCLONE WASHER

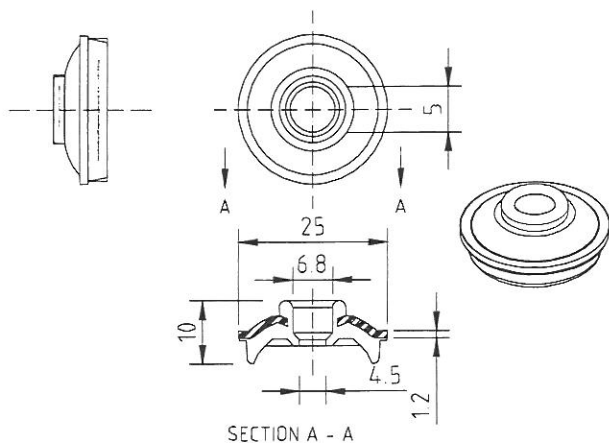

Note:  
All dimensions mm ( nominal )

**Side Lap Fixing**  
**Bremick Vortex™ Stitch M6.5-13 x 20**  
**( 900mm centres min.)**

**FASTENING:**  
STRATCO CORRUGATED  
**0.42mm BMT G550 min.**

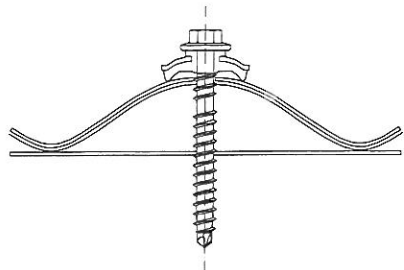

**FASTENING TO:**  
**STEEL PURLINS**  
1.0mm BMT min. **G550 min.**  
1.5mm BMT min. **G450 min.**

**METAL BATTENS**  
**0.75mm BMT min. G550 min.**

**TIMBER BATTENS**  
**F17 Hardwood**

**FASTENING:**  
STRATCO SUPERDEK  
**0.42mm BMT G550 min.**

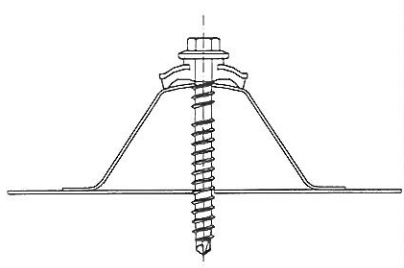

**FASTENING TO:**  
**STEEL PURLINS**  
1.0mm BMT min. **G550 min.**  
1.5mm BMT min. **G450 min.**

**METAL BATTENS**  
**0.75mm BMT min. G550 min.**

**TIMBER BATTENS**  
**F17 Hardwood**

**CORRUGATED ROOFING PROFILE**

**FASTENER SPACINGS**

Crest Fastener Locations : Alternate Ribs (152mm Centres)

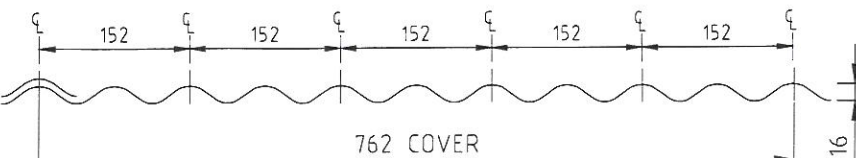

**STRATCO CORRUGATED ROOF CLADDING - ULTIMATE LIMIT STATE DESIGN PRESSURES (kPa)**

| Span Type | Maximum Design Pressure (kPa) for Span L (mm) |      |      |      |      |      |
|-----------|---|------|------|------|------|------|
|           | 600   | 750  | 900  | 1200 | 1500 | 1800 |
| Internal  | 5.98  | 4.64 | 3.75 | 2.63 | 2.04 | 1.65 |
| Equal     | 5.29  | 4.07 | 3.31 | 2.40 | 1.85 | 1.60 |
| Double    | 4.23  | 3.26 | 2.65 | 1.92 | 1.48 | 1.20 |

**SQUARE RIB ROOFING PROFILES**

**FASTENER SPACINGS**

Crest Fastener Locations : Each Rib (190mm Centres)

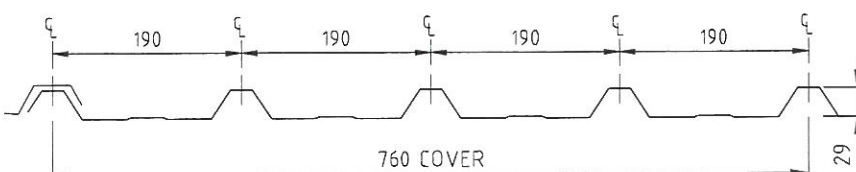

**STRATCO SUPERDEK ROOF CLADDING - ULTIMATE LIMIT STATE DESIGN PRESSURES (kPa)**

| Span Type | Maximum Design Pressure (kPa) for Span L (mm) |      |      |      |      |      |
|-----------|---|------|------|------|------|------|
|           | 600   | 900  | 1200 | 1500 | 1800 | 2100 |
| Internal  | 5.49  | 3.29 | 2.19 | 1.75 | 1.46 | 1.25 |
| Equal     | 4.75  | 2.83 | 2.00 | 1.59 | 1.33 | 1.14 |
| Double    | 3.80  | 2.27 | 1.60 | 1.28 | 1.06 | 0.91 |

Product Name

**Vortex Cyclone - Cyclone Assembly™**

Product Description: Roofing Fasteners  
**M6.2-13x55 & 65 - BRA Cyclone Assembly with Stratco Profiles**

Manufacturer's Details: **BREMICK Pty Ltd**  
88 Dalmeny Ave,  
Rosebery NSW 2018  
Ph: 02 8332 1500  
Email: sales@bremick.com.au

**Design Criteria**

Fastener & support spacing to be controlled such that the maximum design loading per fastener or maximum design pressures do not exceed:

Table 1 : Strength Limit State Design Loads per Fastener

| Roofing Profile | Test Load ( kN ) | C.O.V. ( K <sub>t</sub> ) | Design Load ( kN ) |
|-----------------|------------------|---------------------------|--------------------|
| Corrugated      | 0.73             | 1.38                      | 0.53               |
| Superdek        | 0.83             | 1.38                      | 0.60               |

Description of span types in tables refer to the following support and geometry configurations:

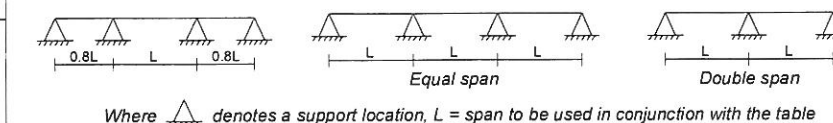

Where denotes a support location, L = span to be used in conjunction with the table

**Limitations**

1. This sheet confirms the structural adequacy of the roof sheeting assembly ( sheeting, screw and washer ) when correctly installed and does not extend to the capacity of the batten/purlin. Refer to the sheeting & batten manufacturers data for maximum support spacings. Axial withdrawal capacity for each fastener exceeds the 3.1kN requirements of AS3566.1: 2002 - Self-drilling screws for building and construction industries - General requirements and mechanical properties. Strength limit state fastener loads have been derived from the test pressures using simplified static analysis with the uniform pressure (load) distribution.

2. Capacity of assembly pullover may be less than sheeting span capacity. Adjust sheeting spans accordingly.

Notes to tables:

- Italic denotes spans that exceed foot traffic limitations.
- Maximum Corrugated spans to suit foot traffic are 1350mm
- Maximum Superdek spans to suit foot traffic are 1350mm

Accepted for Inclusion in Deemed to Comply Manual

DTCM drawing number: **M/347/01**

Chairperson Signature:

Chairperson Name: **Paul Nowland**

Date of Approval: **29/3/2022** Expiry Date: **29/3/2027**

Test Certificate Numbers

JCU Cyclone Testing Station Report TS1221 Cyclic Simulated Wind Load Strength Testing of Roofing Screws and 25mm BRA Washer Assemblies for Roofing Applications. 31st August 2021.

**\*Checking Engineers Certification**

Name: **LEO NOICOS**  
Registration Number: **NER 70762**  
Date: **10.03.2022**  
Signature:

\*registered as a structural engineer in Australia

**\*Certifying Engineers Certification**

Name: **RACHAEL ZEUNER**  
NT Registration Number: **309710ES**  
Date: **10.3.2022**  
Signature:

\*\*registered as a structural engineer in the Northern Territory