

NORTHERN TERRITORY DEEMED TO COMPLY MANUAL – National Construction Code (NCC) Volume 2

This product has been determined to satisfy NCC Performance Requirement H1P1 for structural resistance of materials and forms of construction in high wind areas

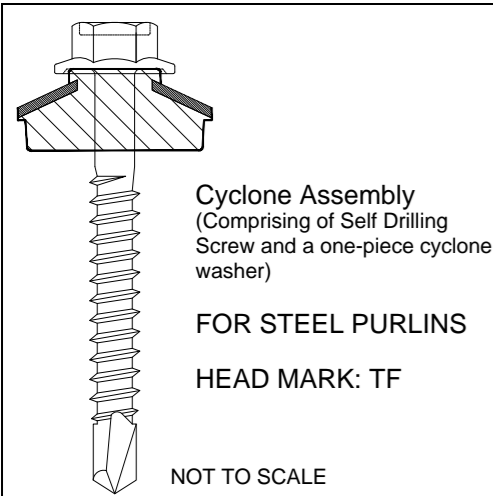

TRAPEZOID ROOFING PROFILE: 0.48bmt Lysaght Spandek Roofing Profile, or equivalent, with a 25mm circular aluminium bonded washer  
 LOCATION OF FIXINGS: Every second rib, screws fixed to support material of 1.5bmt G450 steel purlins  
 OTHER DETAILS: Grade of cladding G550, screw pitch 10 TPI. For all spans greater than 900mm, side laps stitched together at midspan using M6x25mm Zips.

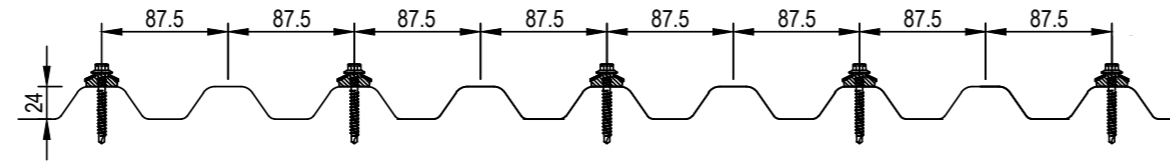

Cladding Profile	Cladding Thickness	Span (mm)	For Cases Where End Spans Are 80% of Internal Spans		For Cases Where End Spans And Internal Spans are Equal	
			Strength Design END SPAN PRESSURE CAPACITY (kPa)	Strength Design INTERNAL SPAN PRESSURE CAPACITY (kPa)	Strength Design END SPAN PRESSURE CAPACITY (kPa)	Strength Design INTERNAL SPAN PRESSURE CAPACITY (kPa)
Spandek (or equivalent)	0.48bmt	600	8.94	8.94	8.13	8.13
		900	6.93	7.24	6.58	6.58
		1200	4.58	5.73	4.58	5.21
		1500	2.87	4.42	2.87	4.02

SELF DRILLING SCREW: SDN414065 #14-10x65mm

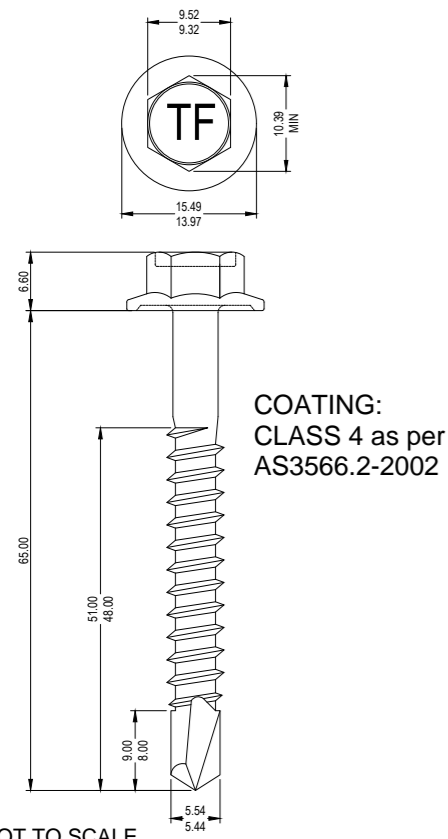

TRAPEZOID ROOFING PROFILE: 0.48bmt Lysaght Trimdek Roofing Profile, or equivalent, with a 25mm circular aluminium bonded washer  
 LOCATION OF FIXINGS: Every rib, screws fixed to support material of 1.5bmt G450 steel purlins  
 OTHER DETAILS: Grade of cladding G550, screw pitch 10 TPI. For all spans greater than 900mm, side laps stitched together at midspan using M6x25mm Zips.

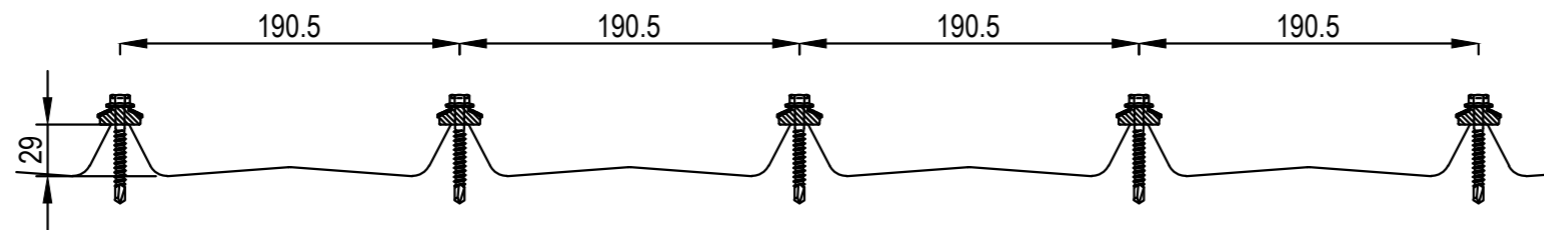

Cladding Profile	Cladding Thickness	Span (mm)	For Cases Where End Spans Are 80% of Internal Spans		For Cases Where End Spans And Internal Spans are Equal	
			Strength Design END SPAN PRESSURE CAPACITY (kPa)	Strength Design INTERNAL SPAN PRESSURE CAPACITY (kPa)	Strength Design END SPAN PRESSURE CAPACITY (kPa)	Strength Design INTERNAL SPAN PRESSURE CAPACITY (kPa)
Trimdek (or equivalent)	0.48bmt	600	8.97	8.97	8.15	8.15
		900	6.60	7.15	6.50	6.50
		1200	4.45	5.56	4.45	5.05

ALUMINIUM BONDED WASHER WITH EPDM SEAL

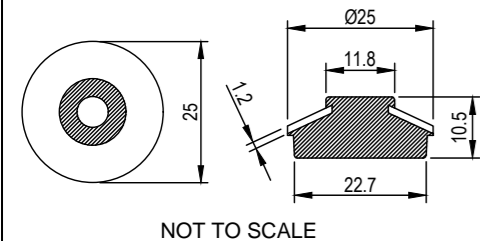

TEST DETAILS: Tests conducted at James Cook University Cyclone Testing Station, Townsville, Queensland  
 - Product tested in accordance with the NCC 2022: Volume 2, Table H1D7 Low-High-Low pressure sequence  
 - Standards: NCC 2022, AS1562.1-2018, AS4040.0-1992, AS4040.3-2018  
 - Test Summary Reports: Report No. TS1286, TS1287, TS1288

Checking Engineer  
 Name: Matthew Mammone  
 Registration Number: 5371177  
 Date: 02/12/2025  
 Signature:   
 Must be an Australian registered structural engineer

Certifying Engineer  
 Name: Trevor John  
 NT Registration Number: 12178ES  
 Date: 02/12/2025  
 Signature:   
 Must be a registered structural engineer in the Northern Territory

Product Name  
 SDN414065-CYC Cyclonic Fastener Assembly by Tri-Fixx Pty Ltd

Product Description  
 Tri-Fixx fasteners for use into trapezoid profile cladding and steel purlins

Manufacturer's Details  
 Tri-Fixx Pty Ltd.  
 11 Tasman Ct, Keysborough, Victoria, Australia 3173  
 P: 03 9543 8422 www.trifixx.com.au

Design Criteria  
 As given in the design tables for each profile and support in the main sheet on LHS

Limitations  
 - The fastener and sheeting capacities are equivalent to materials sourced from the same supplier of rolled formed corrugated sheeting  
 - Testing includes the roof sheeting assembly, i.e. the sheeting screw and cyclone washer, and confirms the adequacy of the assembly when installed correctly  
 - The sheeting, purlin and batten manufacturers' specifications of maximum capacity and support spacing must be referenced  
 - Fasteners to be installed in accordance with manufacturer's specifications

Note  
 Strength Design (Ultimate Limit State as defined in NCC 2022, Volume 2, Table H1D7 Note 1). Pressure Capacity and Strength Design Load per screw have been based on test results which have been carried out in accordance with the Low-High-Low pressure sequence defined in NCC 2022 Volume 2, Table H1D7. The results achieved system compliance at Ultimate Strength Limit loads as detailed in the test report

Accepted for inclusion in Deemed to Comply Manual

DTCM drawing number: M/441/01-01

Chairperson Signature:

Chairperson Name: Elisha Harris

Date of Approval: 11/12/2025 Expiry Date: 11/12/2030