

NORTHERN TERRITORY DEEMED TO COMPLY MANUAL – National Construction Code (NCC) Volume 2

This product has been determined to satisfy NCC Performance Requirement H1P1 for structural resistance of materials and forms of construction in high wind areas

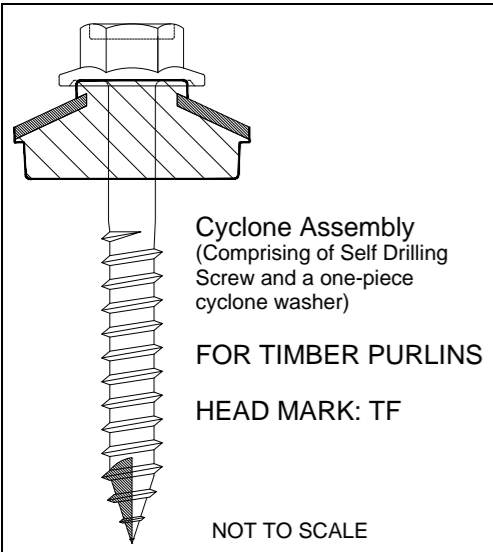

TRAPEZOID ROOFING PROFILE: 0.48bmt Lysaght Spandek Roofing Profile, or equivalent, with a 25mm circular aluminium bonded washer
 LOCATION OF FIXINGS: Every second rib, screws fixed to support material of MGP10 timber purlins, of 41mm min. thickness
 OTHER DETAILS: Grade of cladding G550, screw pitch 10 TPI. For all spans greater than 900mm, side laps stitched together at midspan using M6x25mm Zips.

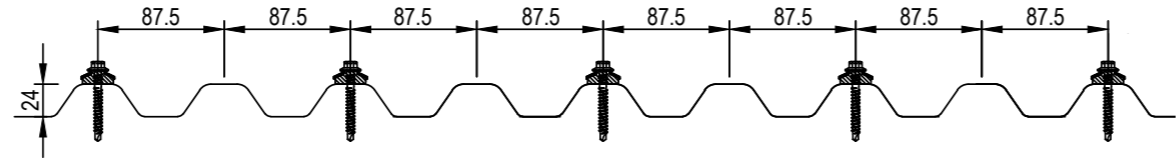

Cladding Profile	Cladding Thickness	Span (mm)	For Cases Where End Spans Are 80% of Internal Spans		For Cases Where End Spans And Internal Spans are Equal	
			Strength Design END SPAN PRESSURE CAPACITY (kPa)	Strength Design INTERNAL SPAN PRESSURE CAPACITY (kPa)	Strength Design END SPAN PRESSURE CAPACITY (kPa)	Strength Design INTERNAL SPAN PRESSURE CAPACITY (kPa)
Spandek (or equivalent)	0.48bmt	600	8.94	8.94	8.13	8.13
		900	6.93	7.24	6.58	6.58
		1200	4.58	5.73	4.58	5.21
		1500	2.87	4.42	2.87	4.02

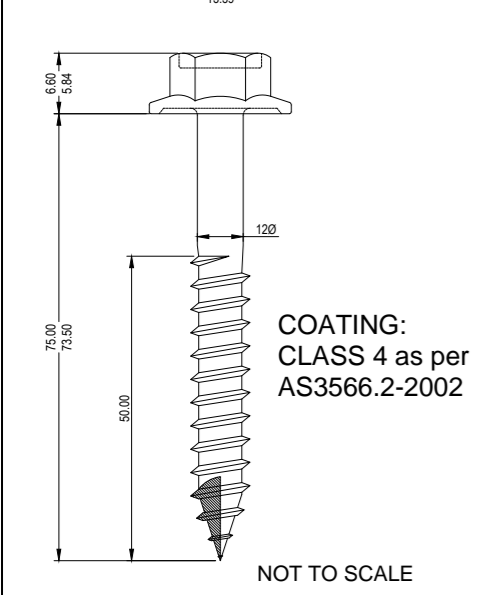
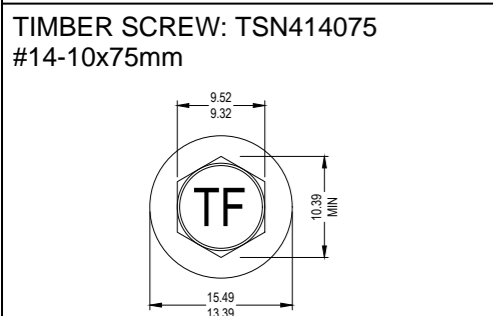

TRAPEZOID ROOFING PROFILE: 0.48bmt Lysaght Trimdek Roofing Profile, or equivalent, with a 25mm circular aluminium bonded washer
 LOCATION OF FIXINGS: Every rib, screws fixed to support material of MGP10 timber purlins, of 45mm min. thickness
 OTHER DETAILS: Grade of cladding G550, screw pitch 10 TPI. For all spans greater than 900mm, side laps stitched together at midspan using M6x25mm Zips.

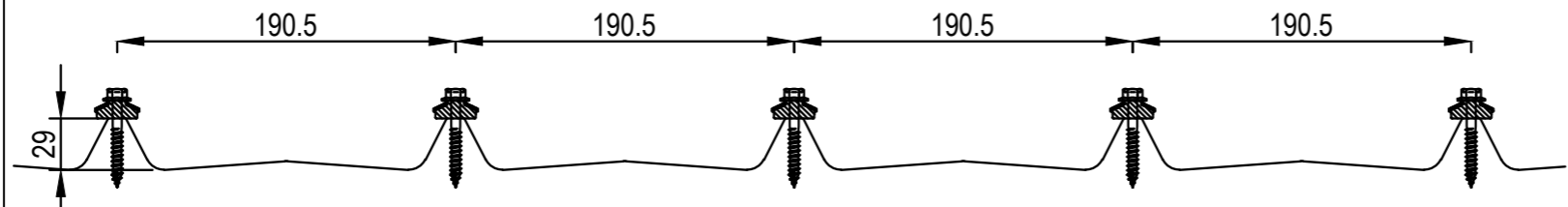

Cladding Profile	Cladding Thickness	Span* (mm)	For Cases Where End Spans Are 80% of Internal Spans		For Cases Where End Spans And Internal Spans are Equal	
			Strength Design END SPAN PRESSURE CAPACITY (kPa)	Strength Design INTERNAL SPAN PRESSURE CAPACITY (kPa)	Strength Design END SPAN PRESSURE CAPACITY (kPa)	Strength Design INTERNAL SPAN PRESSURE CAPACITY (kPa)
Trimdek (or equivalent)	0.48bmt	600	8.97	8.97	8.15	8.15
		900	6.60	7.15	6.50	6.50
		1200	4.45	5.56	4.45	5.05

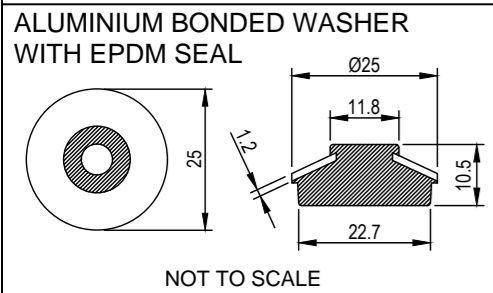

TEST DETAILS: Tests conducted at James Cook University Cyclone Testing Station, Townsville, Queensland

- Product tested in accordance with the NCC 2022: Volume 2, Table H1D7 Low-High-Low pressure sequence
- Standards: NCC 2022, AS1562.1-2018, AS4040.0-1992, AS4040.3-2018
- Test Summary Reports: Report No. TS1286, TS1287, TS1288

Checking Engineer
 Name: Matthew Mammone
 Registration Number: 5371177
 Date: 02/12/2025
 Signature:

Certifying Engineer
 Name: Trevor John
 NT Registration Number: 12178ES
 Date: 02/12/2025
 Signature:

Product Name
 TSN414075-CYC Cyclonic Fastener Assembly by Tri-Fixx Pty Ltd

Product Description
 Tri-Fixx fasteners for use into trapezoid profile cladding and timber purlins

Manufacturer's Details
 Tri-Fixx Pty Ltd.
 11 Tasman Ct, Keysborough, Victoria, Australia 3173
 P: 03 9543 8422 www.trifixx.com.au

Design Criteria
 As given in the design tables for each profile and support in the main sheet on LHS

Limitations

- The fastener and sheeting capacities are equivalent to materials sourced from the same supplier of rolled formed corrugated sheeting
- Testing includes the roof sheeting assembly, i.e. the sheeting screw and cyclone washer, and confirms the adequacy of the assembly when installed correctly
- The sheeting, purlin and batten manufacturers' specifications of maximum capacity and support spacing must be referenced
- Fasteners to be installed in accordance with manufacturer's specifications

Note
 Strength Design (Ultimate Limit State as defined in NCC 2022, Volume 2, Table H1D7 Note 1). Pressure Capacity and Strength Design Load per screw have been based on test results which have been carried out in accordance with the Low-High-Low pressure sequence defined in NCC 2022 Volume 2, Table H1D7. The results achieved system compliance at Ultimate Strength Limit loads as detailed in the test report

Accepted for inclusion in Deemed to Comply Manual

DTCM drawing number: M/443/01-01

Chairperson Signature:

Chairperson Name: Elisha Harris

Date of Approval: 11/12/2025 Expiry Date: 11/12/2030